

ecostore

**2 Door Digital Stainless Steel
Refrigerator, 1430lt (0/+6) with UK
plug-60Hz**

ITEM # _____

MODEL # _____

NAME # _____

SIS # _____

AIA # _____

727435 (RE4142FR60)

 2-door Refrigerator 1430lt,
 0/+6°C, digital, stainless steel
 - UK plug

Short Form Specification

Item No. _____

Two full door refrigerator with internal and external structure in 430 AISI stainless steel; external back panel in galvanized steel and bottom panel in anti-corrosive material. Digital control with cabinet temperature display and setting and manual activation of defrost cycle. Fully compliant HACCP digital controls include visible alarms. Optimized back to front forced air flow provides even temperature distribution and fast cooling in any conditions. Fitted with 75 mm-thick cyclopentane insulating foam. Door features lock and door microswitch to switch off the fan when the door is opened. Hidden evaporator to guarantee higher storage capacity and less corrosion problems. Built-in refrigeration unit; ventilated operation; automatic defrost and evaporation of defrost water. Operating temperature: 0/+6 °C. For ambient temperatures up to 43 °C. CFC and HCFC free. R134a gas in refrigeration circuit.

Main Features

- Two full doors.
- Large storage area suitable to contain 2/1 GN grids or shelves on anti-tilt runners.
- Optimized back to front forced air flow provide even temperature distribution and fast cooling in any conditions.
- Automatic defrost.
- Internal structure with numerous charging positions available to host grids, ensuring higher net capacity and a greater storage space.
- Operating temperatures can be adjusted from 0 to +6 °C to suit both meat and dairy storage requirements.
- Cabinet fitted with up to 75 mm thickness of cyclopentane insulation for best insulating performance with 100% environmental protection (thermal conductivity: 0,020 W/m*K).
- 60 mm-thick insulation covering the evaporator can be easily removed with a single operation.
- Hidden evaporator thus guaranteeing higher storage capacity and less corrosion problems.
- Tropicalized unit.

Construction

- Interior base with rounded corners, pressed from a single sheet.
- External back panel in galvanized steel.
- Stainless steel runners and supports easily disassembled.
- Anti-corrosion bottom material avoids any damage that may be caused to the cabinet by aggressive detergents employed to clean the floors.
- Lockable door.
- Refrigerant type: R134a.
- Doors are self-closing and can be fully opened up to 180°.
- The rounded internal corners, the easily removable runners and grids allow for ease of cleaning and high hygiene standards.
- AISI 430 stainless steel internal structure and external panels.
- Easy access to the main components for maintenance.
- Delivered with UK plug.
- Mounted on wheels.

User Interface & Data Management

- Digital control with cabinet temperature display and setting and manual activation of defrost cycle. Fully compliant HACCP digital controls include visible alarms.
- Easy serviceability thanks to the intuitive control panel with access via app.
- Integrated RS485 port to facilitate connection to a remote computer and integrated HACCP systems.

Sustainability



APPROVAL: _____

- Door switch stops the fan when door is opened to avoid cold air exiting the cell, thus saving energy.
- CFC and HCFC-free insulation.
- Removable triple-chamber balloon magnetic gasket to improve insulation and reduce energy consumption and ease of cleaning.
- Cleaning-free condenser: the structure of the wire frame condenser prevents dust and grease accumulation thus avoiding periodical cleaning operations and reducing energy consumption.
- Automatic evaporation of the defrosting water by hot gas on the top for energy saving.

Included Accessories

- 6 of 2/1GN grey rilsan grid PNC 881020 with 2 runners

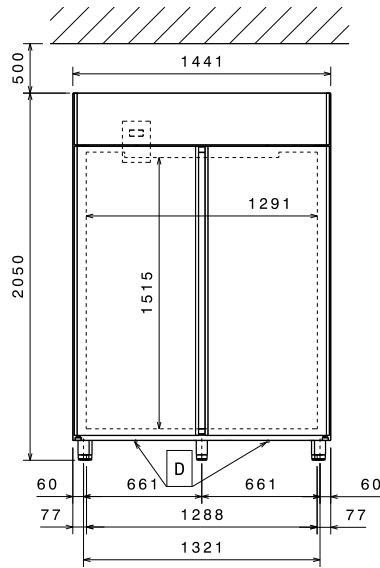
Front



Side

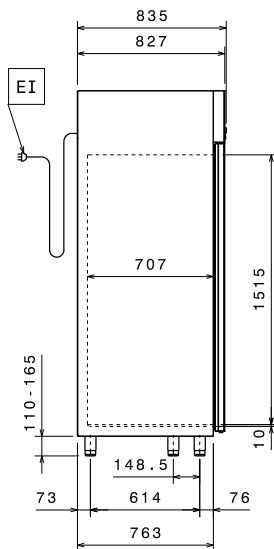

EI = Electrical inlet (power)

Top

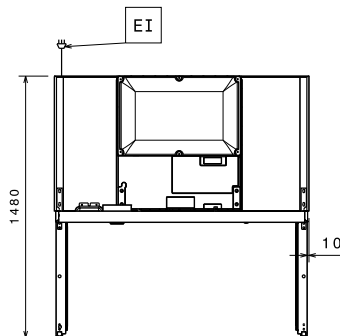
Electric

Supply voltage: 220-230 V/1 ph/60 Hz
 Electrical power, max: 0.33 kW

Capacity:

Number and type of grids (included): 6 - GN 2/1

Key Information:

Door hinges:
 External dimensions, Width: 1441 mm
 External dimensions, Depth: 835 mm
 External dimensions, Depth with Doors Open: 1480 mm
 External dimensions, Height: 2050 mm
 Number and type of doors: 2 Full
 Type of external material: Stainless Steel
 Type of internal material: Stainless Steel
 Internal panels material: Stainless Steel
 Number of positions & pitch: 44; 30 mm
 Gross capacity: 1430 lt

Refrigeration Data

Control type: Digital
 Refrigeration power at evaporation temperature: -10 °C
 Operating temperature min.: 0 °C
 Operating temperature max.: 6 °C
 Operating mode: Ventilated

ISO Certificates

ISO Standards: ISO 9001; ISO 14001; ISO 45001; ISO 50001

Sustainability

Refrigerant type: R134a
 Refrigeration power: 417 W
 Refrigerant weight (unit 1): 170 g